



LL 70 Beam robot

Powerful and reliable

- Modular design
- Dynamic AC servo motors with energy saving features
- Modular control technology with upgrade levels
- Part and gripper weight together: up to 30 kg
- For injection moulding machines up to 8000 kN

Axis	Designation	Stroke (mm)	V max. (m/s)
X	Removal stroke	800 (600)	1.9
Y	Vertical stroke	1600 (2200)	2.6
Z	Transversal stroke	2400 (2100) (2700) (3000)	2.0

Measured cycle

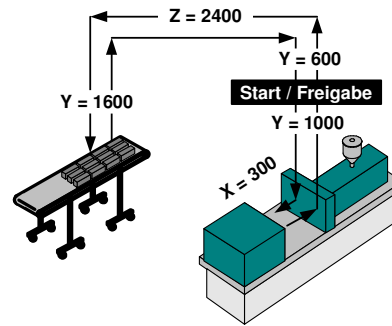

Time of action:
2.3 s

Total cycle-time:
9 s

Dry running period with:
30 kg load

Technical standard specifications

- X-, Y-, Z-axes with AC servo motors
- Repeating accuracy: $\pm 0,1$ mm
- Part and gripper weight together: up to 30 kg
- Mains voltage: 400-480 V (50/60 Hz)
- Power rating: 3500 VA
- Compressed air supply: 6 bar, consumption approx. 2 NI/cycle (without vacuum)
- Y-axis telescopic
- Two compressed air circuits and two vacuum circuits
- Freely programmable control EasyControl including EasyTeach
- All the standard Euromap 67 signals

Options

- Single-stage axes
- Additional compressed air circuits and vacuum circuits
- Pneumatic A, B and C rotation modules
- Motor drive A and B rotation module
- PC programming software (offline) EasySoft
- Linkage of the hardware by means of Ethernet
- CAN islands for controlling the peripheral devices
- USB port for program backup
- Upgrade Kit ComfortControl, ComfortTouch included for graphic user interface (in place of EasyControl)
- Euromap 12
- Further options upon request

All indications and images are without guarantee and can change at any time.

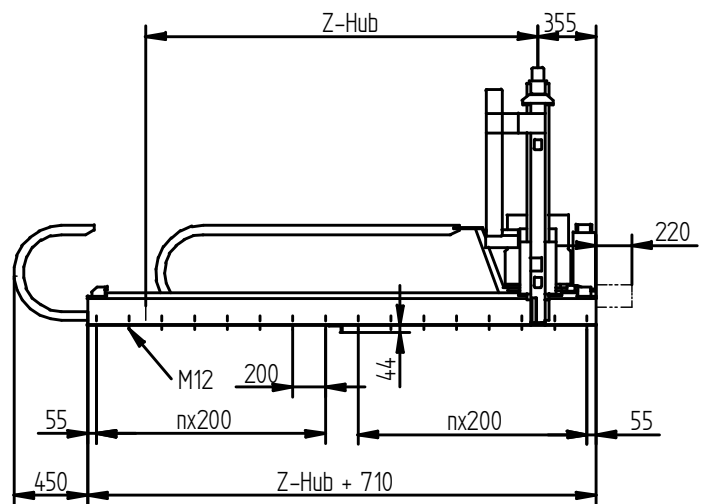
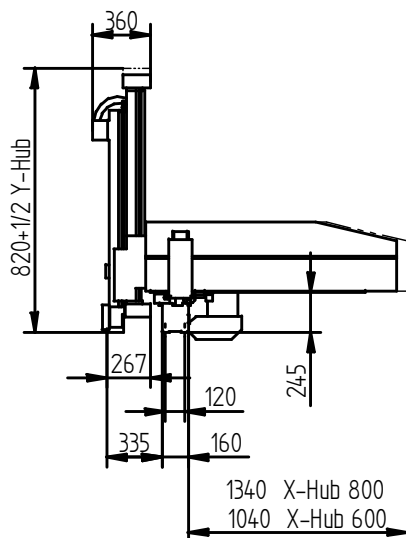

Headquarter

GHS Automation AG
Steinhaus, CH-3150 Schwarzenburg
Phone +41 (0)31 734 31 11
Telefax +41 (0)31 734 31 00
E-Mail: info@ghsautomation.com