



ML 50 Double Y Beam robot

Designed for 3-plate mould applications

- Two vertical strokes – Y1 for parts removal – Y2 for removal of sprues
- Multifarious possibilities of application due to stard X-axis
- Dynamic AC servo motors with energy saving features
- Highly dynamic drive system
- Modular control technology with upgrade levels
- For injection moulding machines up to 3000 kN
- Part and gripper weight together: up to 6 kg (0.3 kg for sprue)

Axis	Designation	Stroke (mm)	V max. (m/s)
X1 X2	Removal stroke: -motorbased -pneumatic	500 0-80 *	1.37
Y1 Y2	Vertical stroke -motorbased -pneumatic	1000 (1200) 800	4.1
Z	Transversal stroke	1600 (1900) (2200) (2500) (3100)	3.3

* adjustable

Measured cycle

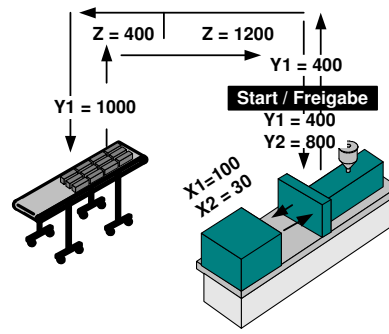

Time of action Y1:
1.1 s
Time of action Y2:
2.6 s

Total cycle-time:
6.5 s

Dry running period with:
6.0 kg load (Y1)
0.3 kg load (Y2)

Technical standard specifications

- X1-, Y1-, Z-axes with AC servo motors
- X2-, Y2-axes pneumatic
- Repeating accuracy: Y1 $\pm 0,1$ mm / Y2 $\pm 0,5$ mm
- Part and gripper weight together: Y1 up to 6 kg / Y2 up to 0.3 kg
- Mains voltage: 400-480 V (50/60 Hz)
- Power rating: 2000 VA
- Compressed air supply: 6 bar, consumption approx. 2 NI/cycle (without vacuum)
- Two compressed air circuits and two vacuum circuits
- Y2 with gripper K
- Rotation module C0 (0/90°)
- Freely programmable control EasyControl including EasyTeach
- All the standard Euromap 67 signals

Options

- Metal grippers
- Gripper monitoring feature
- Additional compressed air circuits and vacuum circuits
- Pneumatic A and B rotation modules
- Motor driven B rotation module
- PC programming software (offline) EasySoft
- Linkage of the hardware by means of Ethernet
- CAN islands for controlling the peripheral devices
- USB port for program backup
- Upgrade Kit ComfortControl, ComfortTouch included for graphic user interface (in place of EasyControl)
- Euromap 12
- Without X2-axis, in place X1-removal stroke X=600mm
- X1-axis as telescope (two-stage)
- Further options upon request

All indications and images are without guarantee and can change at any time.

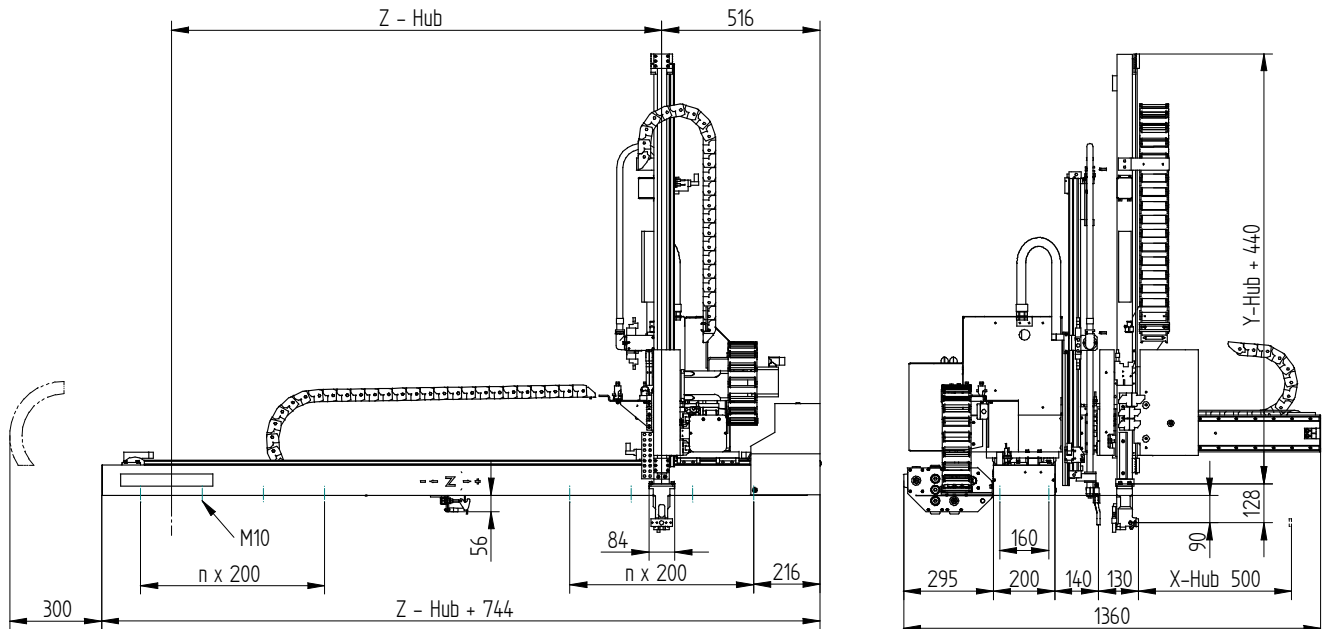

Headquarter

GHS Automation AG
Steinhaus, CH-3150 Schwarzenburg
Phone +41 (0)31 734 31 11
Telefax +41 (0)31 734 31 00
E-Mail: info@ghsautomation.com