



ML 60 Beam robot

Versatile, for complex automation projects

- Large variety of versions and enhancements
- Dynamic AC servo motors with energy saving features
- Modular control technology with upgrade levels
- Part and gripper weight together: up to 15 kg
- Robust mechanical construction
- For injection moulding machines up to 4000 kN

Axis	Designation	Stroke (mm)	V max. (m/s)
X	Removal stroke	600 (400)	1.2
Y	Vertical stroke	1000 (800) (1200) (1500)	4.7
Z	Transversal stroke	1600 (1900) (2800) (2200) (3100) (2500) (3700)	3.5

Measured cycle

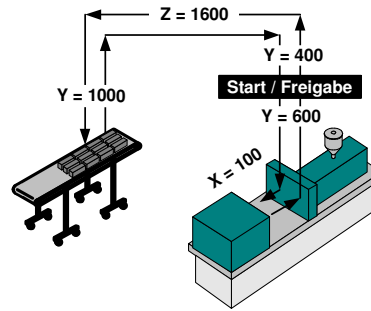

Time of action:
1.5 s

Total cycle-time:
4.6 s

Dry running period with:
15 kg load

Technical standard specifications

- X-, Y-, Z-axes with AC servo motors
- Repeating accuracy: $\pm 0,1\text{mm}$
- Part and gripper weight together: up to 15 kg
- Mains voltage: 400-480 V (50/60 Hz)
- Power rating: 2000 VA
- Compressed air supply: 6 bar, consumption approx. 2 NI/cycle (without vacuum)
- Two compressed air circuits and two vacuum circuits
- Rotation module C1 (0/90°)
- Freely programmable control EasyControl including EasyTeach
- All the standard Euromap 67 signals

Options

- X-stroke 800 mm at a reduced speed and weight
- Additional compressed air circuits and vacuum circuits
- Pneumatic A- and B rotation modules
- Motor drive B rotation module
- PC programming software (offline) EasySoft
- Linkage of the hardware by means of Ethernet
- CAN islands for controlling the peripheral devices
- USB port for program backup
- Upgrade Kit ComfortControl, ComfortTouch included for graphic user interface (in place of EasyControl)
- Euromap 12
- Further options upon request

All indications and images are without guarantee and can change at any time.

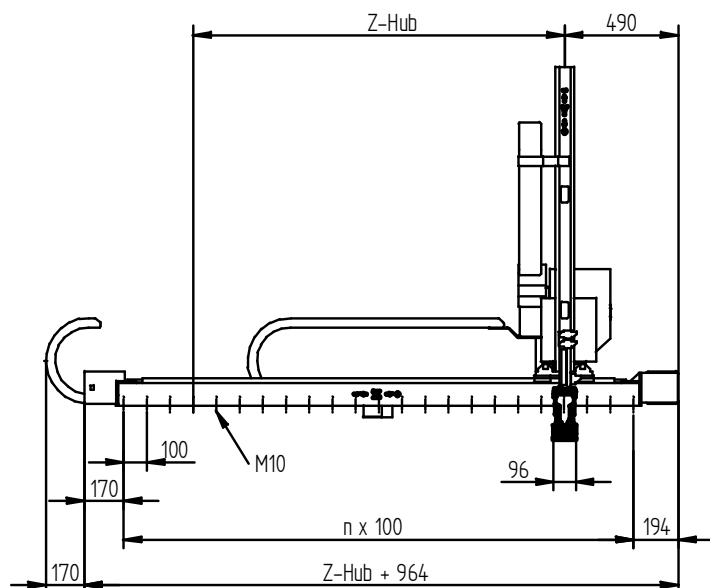
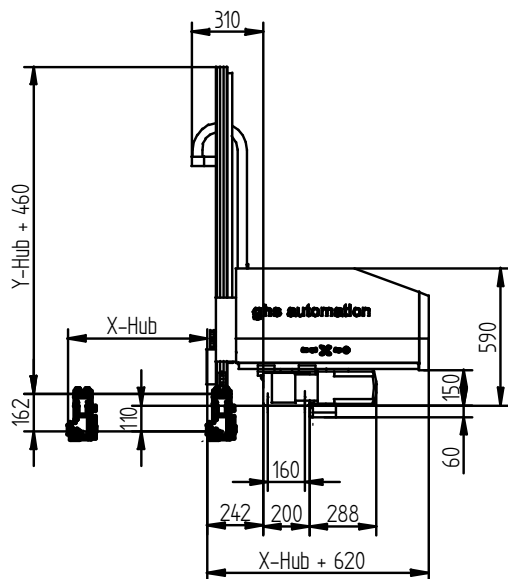

Headquarter

GHS Automation AG
Steinhaus, CH-3150 Schwarzenburg
Phone +41 (0)31 734 31 11
Telefax +41 (0)31 734 31 00
E-Mail: info@ghsautomation.com