

SL 10 Servo-Handling

Unload handler for small injection moulding machines

- Dynamic AC servo motors for accurate, infinite positioning
- All the axes can be freely programmed
- Simple operation and maintenance
- Minimum energy consumption
- For removal of sprues and parts weighing up to 3 kg
- For injection moulding machines up to 2500 kN

Axis	Designation	Stroke (mm)	V max. (m/s)
X	Removal stroke	mech. -150mm motor max 300 mm (motor max 500 mm)	0.4
Y	Vertical stroke	800 (1000)	1.5
Z	Transversal stroke	1300 (1000) (1600) (1900) (2200)	1.3

Measured cycle

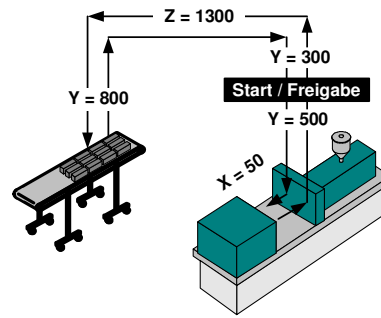

Time of action:
2 s

Total cycle-time:
8 s

Dry running period with:
3 kg load

Technical standard specifications

- All the axes with servomotors
- X, Y and Z-axis with linear guidance
- Repeating accuracy: $\pm 0,1$ mm
- Part and gripper weight together: up to 3 kg
- Mains supply: 230/115 V (50/60 Hz)
- Power rating: 110 VA
- Compressed air supply: 6 bar, consumption approx. 0,5 NI/cycle (without vacuum)
- One compressed air and one vacuum circuit
- Rotation module C0 (0/90°) with monitoring feature
- Freely programmable control MiniControl including EasyTeach
- All the standard Euromap 67 signals

Options

- Additional compressed air and vacuum circuit
- Rotation module B with monitoring feature
- Blow-off function for the compact ejectors
- PC programming software (offline) EasySoft
- Disk drive unit for data safeguarding
- A linkage of the hardware by means of RS485
- CAN islands for controlling the peripheral devices
- Euromap 12
- Further options upon request

All indications and images are without guarantee and can change at any time.

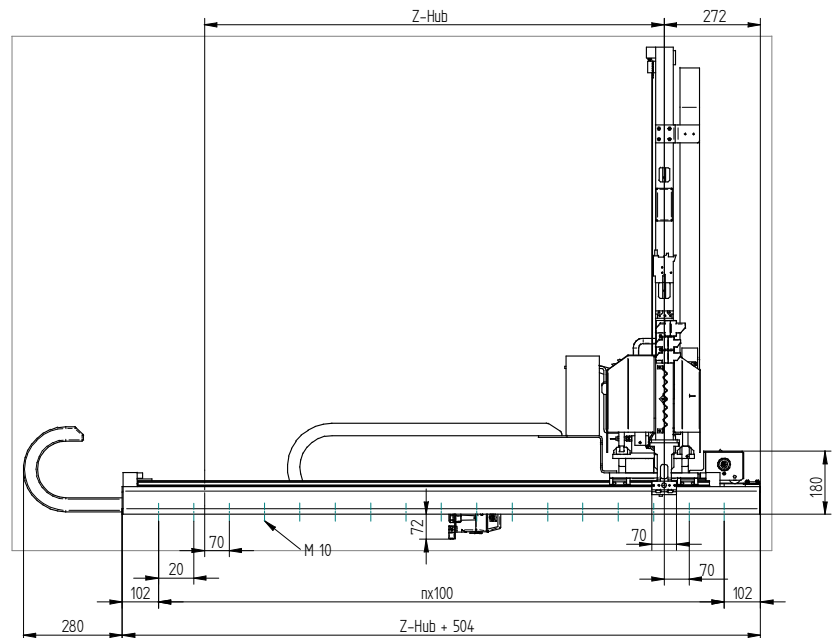
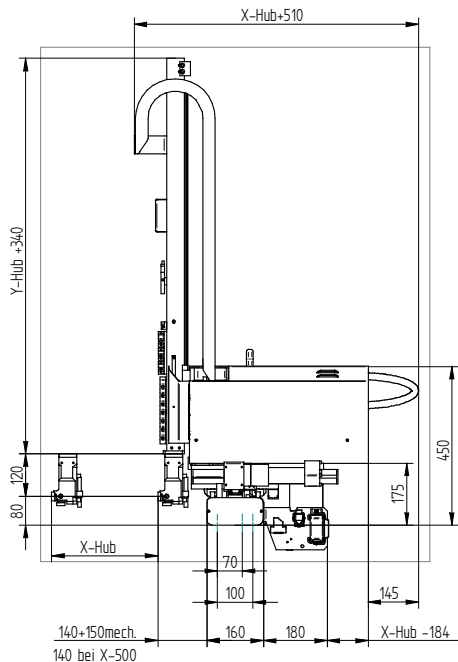

Headquarter

GHS Automation AG
Steinhaus, CH-3150 Schwarzenburg
Phone +41 (0)31 734 31 11
Telefax +41 (0)31 734 31 00
E-Mail: info@ghsautomation.com

15.11.2007